

+12

TREXER

USER MANUAL

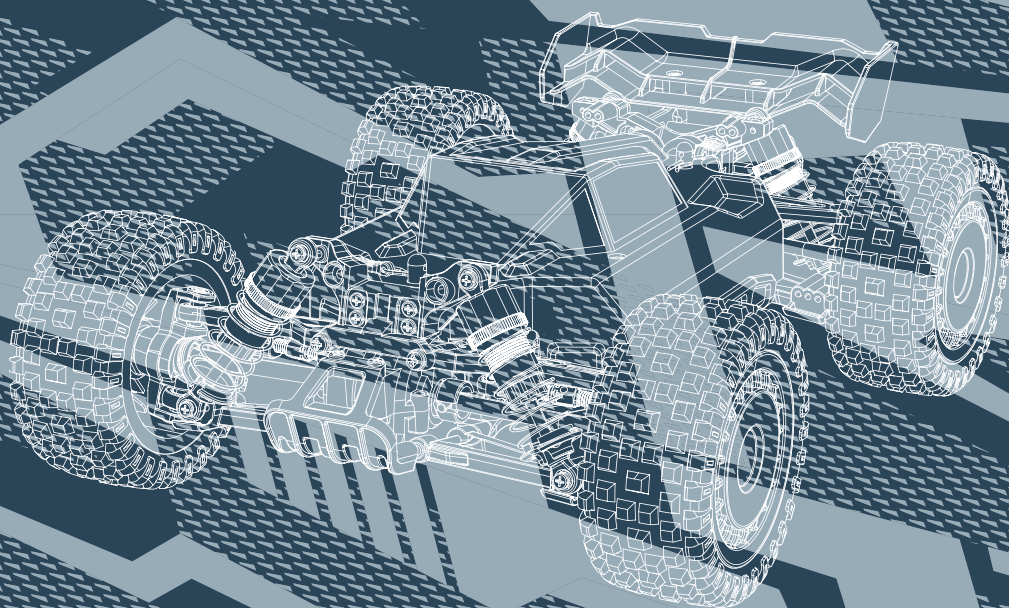

ZERO-X

ZX-RCP

CONTENTS

1.0 WELCOME.....	4
2.0 IN THE BOX:.....	4
3.0 BATTERY SAFETY	5
4.0 RECHARGEABLE BATTERY CHARGING.....	9
5.0 POWERING ON	10
6.0 R30 RECEIVER	10
7.0 E45A BRUSHLESS ESC	11
8.0 REMOTE CONTROL	12
9.0 HEAD WHEEL INSTALLATION (OPTIONAL).....	13
10.0 REAR WING INSTALLATION	14
11.0 REMOTE CONTROL BATTERY INSTALLATION	14
12.0 CAR SHELL ASSEMBLY	14

1.0 WELCOME

Thank You for purchasing a Zero-X Remote Control Car. The Zero-X range has been specifically designed to provide the intermediate to advanced user with a great driving experience. Please take the time to read the following safety warnings and operating instructions carefully.

2.0 IN THE BOX:

- RC Car Trexer x1
- Remote Control x1
- Battery (Standard Package) x2
- Rear Wing (with 2 screws) x1
- User Manual x1
- USB Charging Cable x1
- Hexagon Wrench x1
- Head Wheel (with 3 screws) x1
- Screwdriver x1
- 3M Action Camera Mounting Plate x1

3.0 BATTERY SAFETY

IMPORTANT INFORMATION - PLEASE READ BEFORE USE

When handled incorrectly, Lithium polymer batteries can be dangerous and can potentially harm persons and / or property. Zero-X does not accept any liability for damage to persons and/ or property, if the battery is not correctly charged, stored or protected.

These are our suggestions to keep safe:

- Always unwind all cables before charging.
- **DO NOT** over charge the battery. Once the charging process is completed, remove the battery from the charger.
- Only use the included or replacement Zero-X chargers and batteries.
- You must charge the Lithium polymer battery in a safe area away from flammable materials.
- The battery is only to be charged under adult supervision. Do not leave charging batteries unattended. Remain aware of the charging process so you can react immediately to any problems that may occur.
- **DO NOT** charge the battery in temperatures higher than 40°C or lower than 0°C.
- **DO NOT** cover the batteries when charging. **DO NOT** leave batteries in direct sunlight.
- After each flight and / or crash, please check battery for any damage or swelling.
- If the battery is damaged, leaking, making noises, punctured or malformed in any way **DO NOT** attempt to use it. Please dispose of the battery immediately and safely in the correct manner.
- **DO NOT** bend, puncture, crush or scratch the battery.
- **DO NOT** store batteries in your pockets, on you or in extreme temperatures.
- After flying/discharging the battery you must allow it to cool to ambient/room temperature before recharging.
- If at any time during the charge or discharge process the battery begins to balloon or swell, discontinue charging or discharging immediately. Quickly and safely disconnect the battery, then place it in a safe, open area away from flammable materials to observe it for at least 15 minutes. **Continuing to charge or discharge a battery that has begun to balloon or swell can result in a fire.** A battery that has ballooned or swollen even in a small amount must be removed from service completely.
- Never plug in a battery and leave it to charge unattended overnight.
- Non-compliance with the above warnings may result in the failure of the battery and become dangerous. The instruction sheet for this product is just for your reference. We reserve the right to make changes or adjustments on the product without prior notification. Please refer to the official information.

WARNING:

Choking hazard! This product contains small parts. NOT suitable for children under 3 years. Contains electrical components and should be kept dry at all times. Regularly check the battery charger wires, plugs and shell and other components for damage. DO NOT use if any part is damaged.

WARNING AND CAUTIONS

1. Detachable small parts should be stored safely and out of reach of children.
2. If interference is experienced, turn off the car and try it again at a different area.
3. The remote control will not function correctly if battery power is low. Please replace the batteries.
4. Please discard old/used batteries in a safe manner.
5. Please store the remote control car in cool, dry place.
6. DO NOT expose the car to fire or high temperatures or store in a moist location.
7. If the battery is wet, wipe immediately with a soft dry cloth. Stop using the car immediately if the battery is damaged or deformed.
8. If the car is not used for prolonged periods, please hang up the car with the chassis raised.

PRECAUTION FOR BATTERY USE

1. The remote control uses two 1.5V AA-size batteries (batteries not included).
2. Please ensure the correct polarity when replacing batteries.
3. Rechargeable batteries should be charged under adult supervision.
4. Do not mix old and new batteries. Do not mix alkaline, standard (carbon-zinc), or rechargeable batteries.
5. After the batteries are exhausted, it should be removed from the remote control.
6. Please dispose of exhausted batteries safely and responsibly.
7. DO NOT short circuit any terminals.
8. DO NOT attempt to recharge non rechargeable batteries.
9. Please remove the rechargeable battery from the car for charging.
10. DO NOT place batteries into a fire or water.
11. The rated input voltage battery charger MUST be suitable for your mains power voltage.
12. During charging, it is quite normal for the charger and battery to heat up.
13. Do not swallow the batteries.
14. Store the batteries in a cool and dry location and out of reach of children.
15. If the battery leaks and the liquid enters into your eyes, please rinse your eyes immediately and seek medical attention.

SAFETY PRECAUTIONS

- The remote control car is not a toy. Please handle it appropriately.
- The car requires a simple assembly before use.
- Improper usage with alkaline cells or rechargeable batteries may damage the electronics of the car or the remote control.

In order to operate the car safely, please observe the following points:



- Please read the user manual carefully and thoroughly before using the car. Seek advice if you need help to assemble the car.



- Please handle all tools carefully.



- The car contains small and sharp parts. Please assemble and store the car away from the presence of young children.

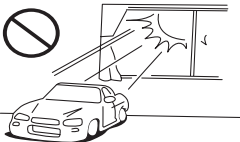

- Do not expose the car to direct sunlight, excessive humidity or high temperatures.



- Never reverse the polarity or disassemble the battery as it may cause damage and leakage of the battery.
- When not in use, always turn off the remote control. In addition, disconnect the batteries and remove them from the car and the remote control. This is to avoid overheating and leakage.



OPERATING THE CAR SAFELY

Do NOT operate the car in the following places and situations.

1. On public roads or areas of high traffic.
 2. In places that are crowded and where infants and children gather.
 3. In residential areas and public parks.
 4. Indoors and where space is limited.
- Please stop using the car if it is operating abnormally. Check for the problem and if it is not rectified, stop using the car immediately to prevent any further problems or issues from occurring.
 - Always check that the remote control batteries are working properly with ample power level. With weak dry batteries, the remote control may fail with transmission and reception. You may also lose control of the car and cause potential accidents.
 - Keep in mind that people around you may also be operating a radio control car. NEVER share the same frequency with somebody else at the same time! Otherwise, radio signals will be mixed up and you will lose control to your car. This may lead to accidents.
 - Do not place fingers or any object inside the rotating and moving parts of the car.
 - Do not touch the motor right after the use of the car as you may suffer burns.

4.0 RECHARGEABLE BATTERY CHARGING

Install the battery:

1. Turn the knob and open the battery holder as shown in Step 1.
2. Remove the rechargeable battery (11.1V 1050mAh 25C) and charge it using the supplied USB charging cable or the power adaptor as shown in Step 2 and Step 3.
3. When charging, the indicator light on the USB charging cable will turn green and blink and will stay a constant green when the battery is fully charged. A full charge will take approximately 4 hours.
4. After the rechargeable battery is fully charged, re-install it to the car as shown in Step 4.
5. Replace the battery holder and turn the knob to secure it as shown in Step 5.

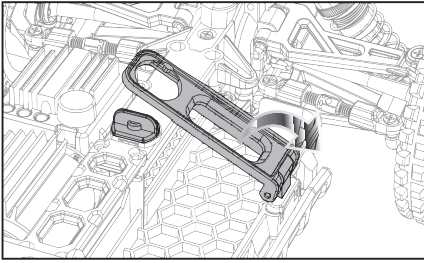

Step 1

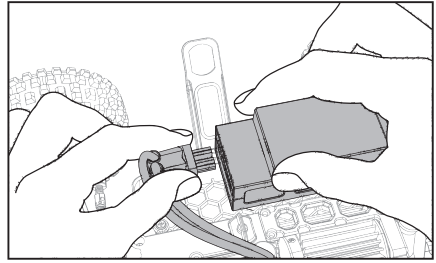

Step 2

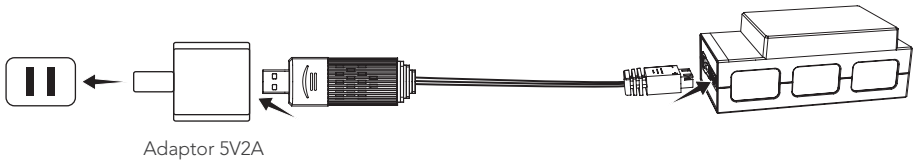

Step 3

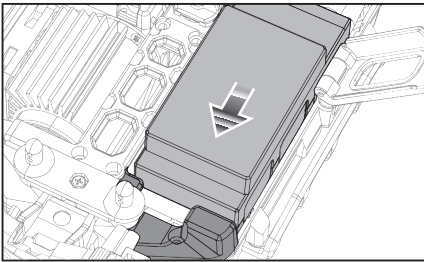

Step 4

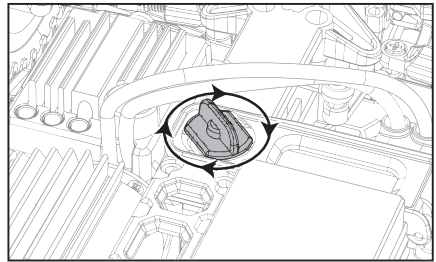

Step 5

5.0 POWERING ON

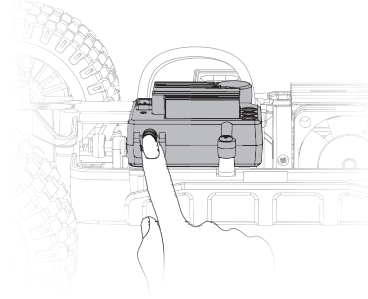
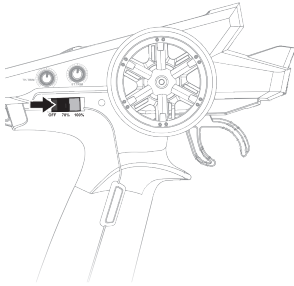

1. Please turn on the remote control first.
 2. Next, turn on the car. The LED indicator will blink in red. Please **DO NOT** touch the throttle knob and steering on the remote control.
 3. The LED indicator on the car will change to a constant red.
 4. Please assemble the top shell to the car.
 5. Only pair one car with one remote control at the same time to prevent any failed connection.
- Please **DO NOT** touch the throttle and steering. After turning on the remote control, use it only after the LED light has become a constant red.
 - Please ensure that the remote control is always turned on first before turning on the car.
 - When pairing the frequencies of the car and remote control, please ensure that it is only between these two items. Otherwise, the frequencies pairing will be unsuccessful.

6.0 R30 RECEIVER

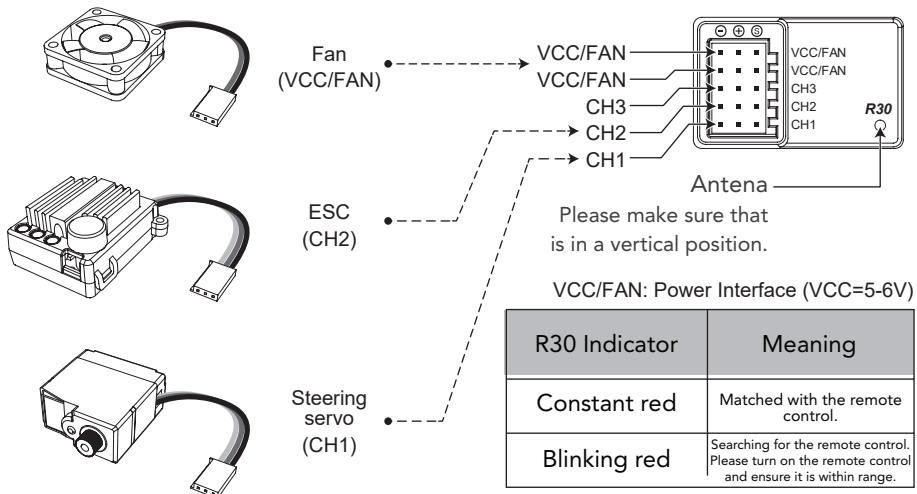

Warning: Please make sure the connection is correct.

⑤ ST (Steering)

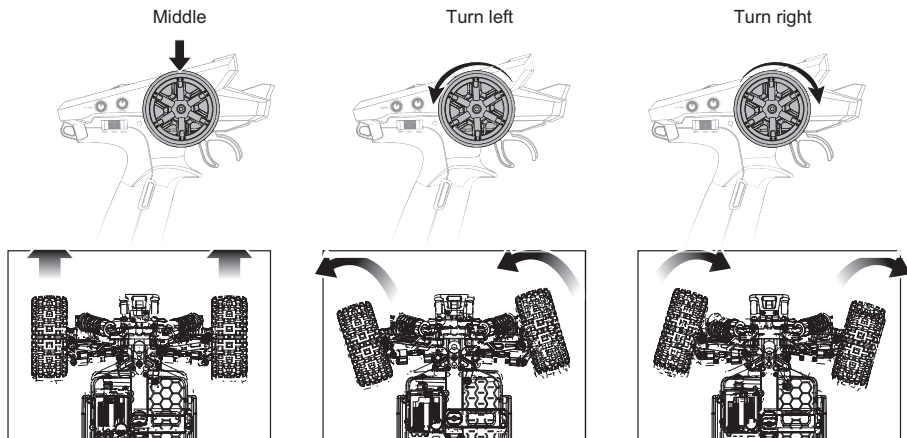

⑥ TH (Throttle)

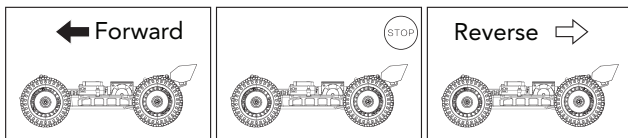
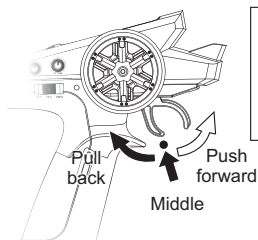

Brake: To brake, squeeze the remote control trigger to its middle position to stop the car. Squeeze the trigger further back to reverse the car.

7.0 E45A BRUSHLESS ESC



Please Do Not force or reverse insert all sockets.

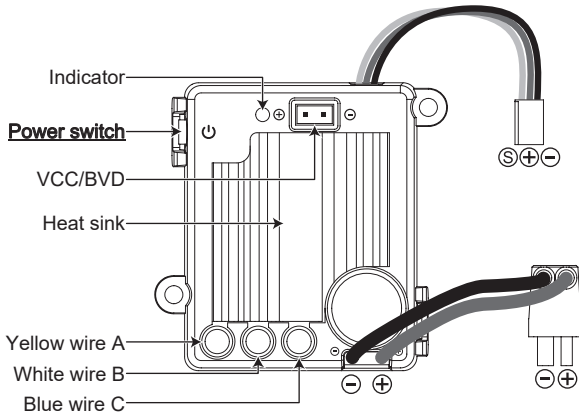

E45A Indicator	Meaning
Constant red	Matched with the remote control.
Blinking red rapidly	Low Voltage
Blinking red slowly	Overheating Protection
Blinking red twice	The motor is stuck and stuck protection is activated.
Off	Off

8.0 REMOTE CONTROL

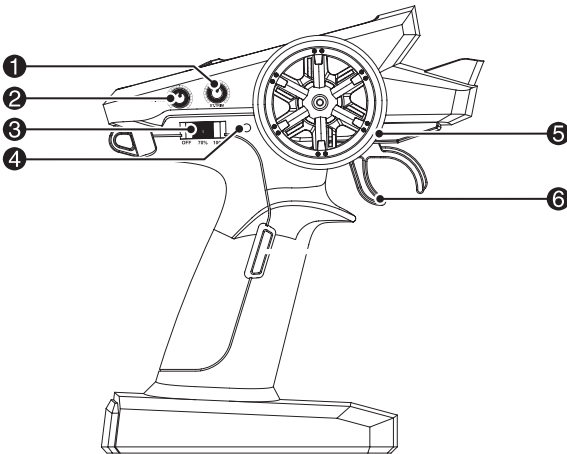

- ① ST TRIM
(Steering servo trimmer)
- ② TH TRIM
(Throttle trimmer)
- ③ Power switch
(Power Switch/Throttle Sensitivity)
- ④ Indicator Light
- ⑤ ST (Steering)
- ⑥ TH (Throttle)

① **ST TRIM (Steering servo trimmer)**

If the car is not heading straight, it can be corrected via the ST TRIM.

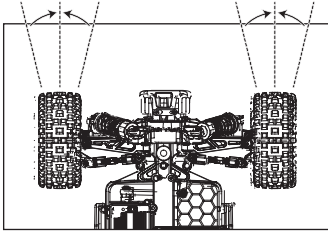

② **TH TRIM (Throttle trimmer)**

If the car cannot be stopped when the TH is at the middle position, use TH TRIM to adjust the stopping action.

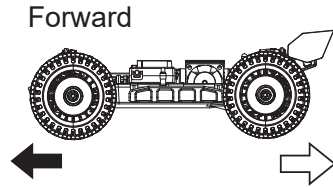

③ **Power Switch/Throttle Sensitivity**

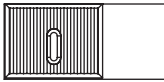

OFF 70% 100%

OFF 70% 100%
(70% Throttle) (100% Throttle)

④ **Indicator Light**

Stays constant: Working normally

Blinks rapidly: Pairing with remote control

Blinks slowly: Remote control battery level low

9.0 HEAD WHEEL INSTALLATION (OPTIONAL)

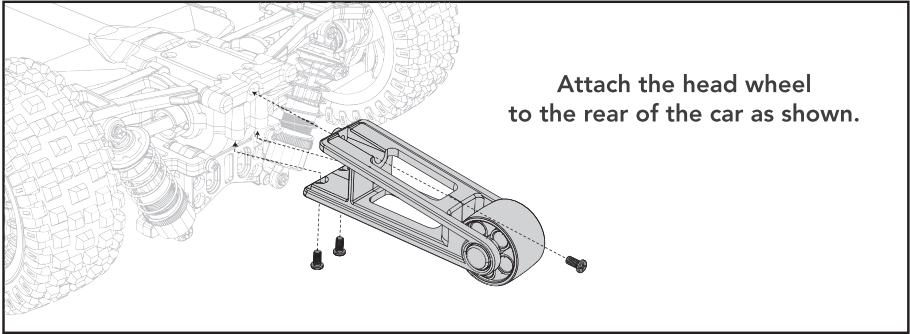

 Please install the accessory according to your needs.

To obtain better grip and straight-line driving on a flat surface, attach the head wheel to the car.

However, on uneven terrain, we do not recommend attaching the head wheel as it will reduce the off-road performance of the car. At the same time, the head wheel may also be damaged when performing stunts.

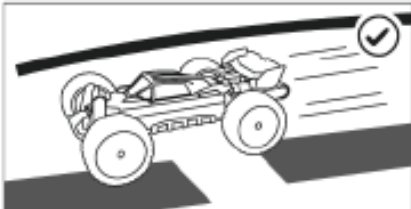

Flat and even ground such as cemented or asphalt surfaces.

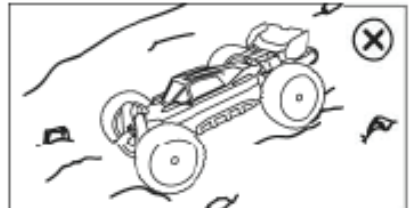

Uneven terrain such as rough and gravel surfaces.

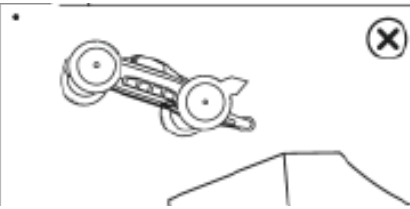

Car stunts from ramps.

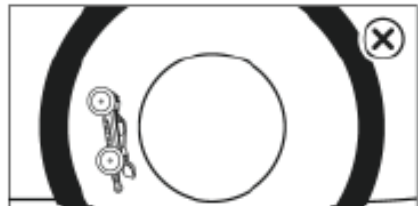

Barrel rolls in cement pipes.

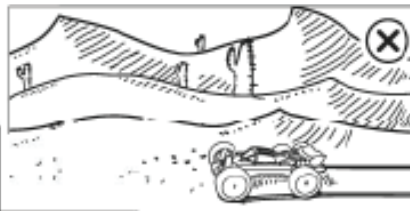

Sandy surfaces such as beaches and deserts.



Turfed and grassy areas.

10.0 REAR WING INSTALLATION

Install the rear wing with the two screws supplied.

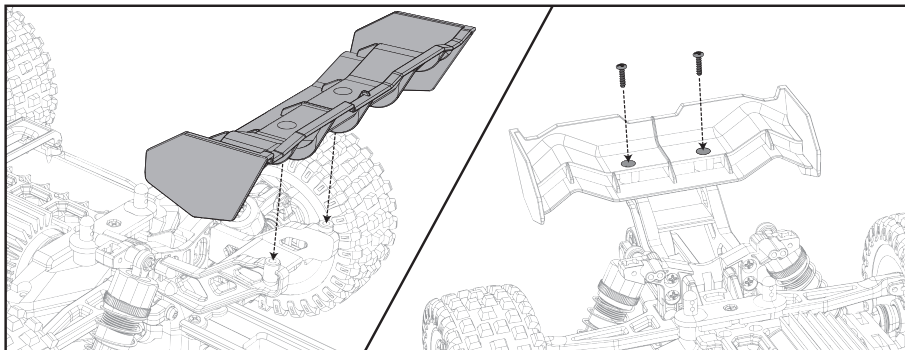

11.0 REMOTE CONTROL BATTERY INSTALLATION

Open the battery cover by removing the two screws with the supplied screwdriver. Then insert two AA-size batteries (not included) into the battery compartment and ensure that the polarity is correct. Close the cover after installation.

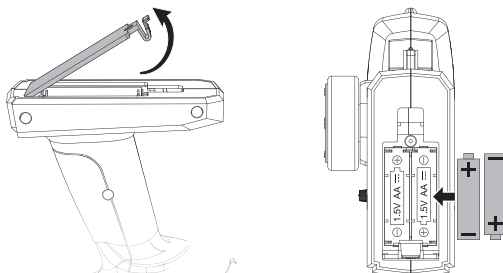

12.0 CAR SHELL ASSEMBLY

1. To assemble the car shell, align the holes on the car shell with the corresponding struts on the car chassis. There is one strut in front and two struts behind.

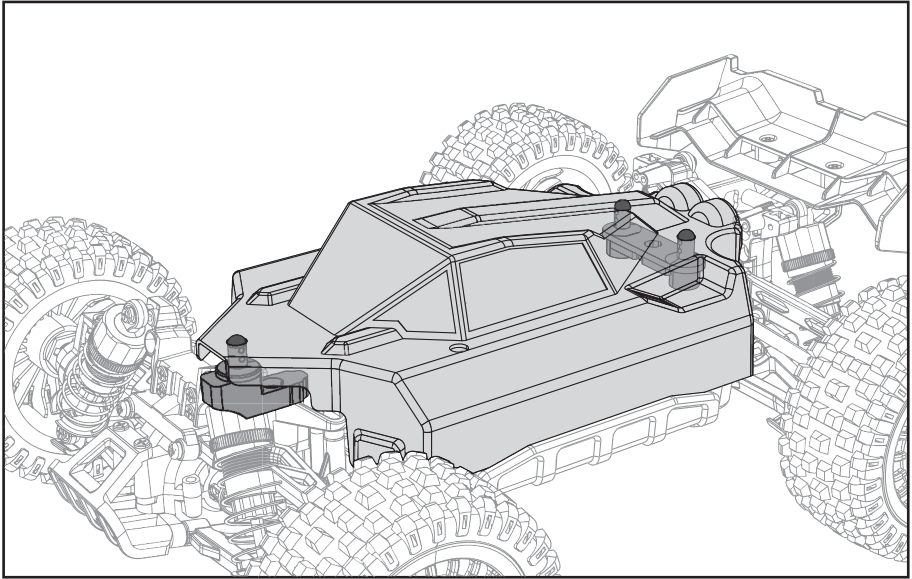

2. Insert the 3 pins into the struts to secure the assembly. To disassemble, repeat the steps in reverse order.

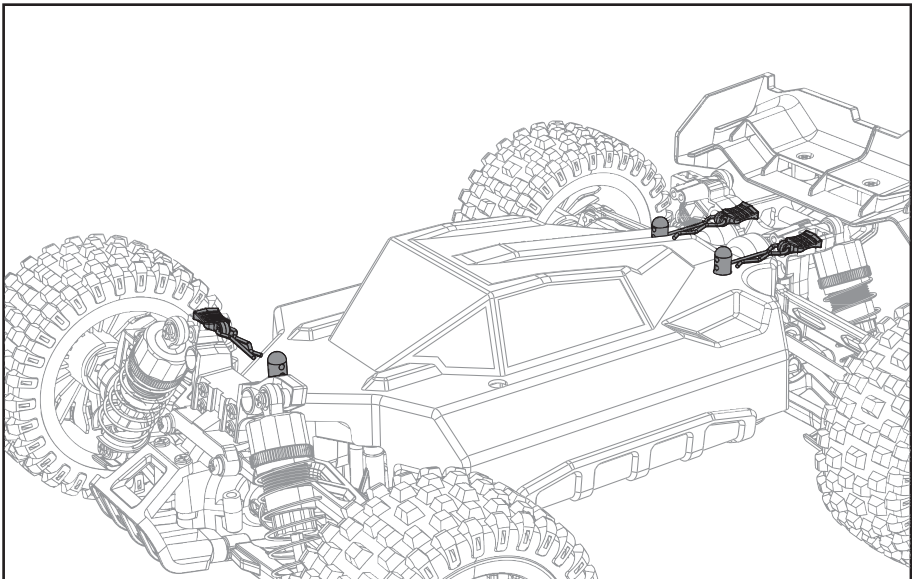

WARRANTY TERMS AND CONDITIONS

Our goods come with guarantees that cannot be excluded under the Australian Consumer Law. You are entitled to a replacement or refund for a major failure and for compensation for any other reasonably foreseeable loss or damage. You are also entitled to have the goods repaired or replaced if the goods fail to be of acceptable quality and the failure does not amount to a major failure.

This warranty is provided in addition to your rights under the Australian Consumer Law. Directed Electronics Australia Pty Ltd (Directed Electronics) warrants that this product is free from defects in material and workmanship for a period of 12 months from the date of purchase or for the period stated on the packaging. This warranty is only valid where you have used the product in accordance with any recommendations or instructions provided by Directed Electronics.

This warranty excludes defects resulting from alterations of the product, accident, misuse, abuse or neglect. In order to claim the warranty, you must return the product to the retailer from which it was purchased or if that retailer is part of a National network, a store within that chain, along with satisfactory proof of purchase. The retailer will then return the goods to Directed Electronics.

Directed Electronics will repair, replace or refurbish the product at its discretion. The retailer will contact you when the product is ready for collection. All costs involved in claiming this warranty, including the cost of the retailer sending the product to Directed Electronics, will be borne by you.

Email: admin@zero-x.com.au

INDEMNITY

You agree to defend, indemnify and hold harmless Zero-X and its subsidiaries and affiliates from and against any and all claims, proceedings, injuries, liabilities, losses, costs and expenses (including reasonable legal fees), including but not limited to, claims alleging negligence, invasion of privacy, copyright infringement and/or trademark infringement against Zero-X and its subsidiaries and affiliates, relating to or arising out of your breach of any provision of these terms, your misuse of Zero-X products or its services, or your unauthorized modification or alteration of products or software.

WARRANTY AND WARRANTY DISCLAIMER

Zero-X has a limited warranty, whereby Zero-X warrants to you and only to you that this Zero-X product will be free from defects in materials and workmanship for one (1) year from the date of your purchase (unless a longer warranty period is required by law). The specifics of this Zero-X limited warranty are covered in this manual.

To the extent possible under governing law, other than the above product warranty for the Zero-X product you understand and agree that the Zero-X

services are provided on an “as is” and “as available” basis.

Zero-X makes no warranty that the Zero-X product and services will meet your requirements or that use of the Zero-X services will be uninterrupted, timely, secure or error-free. Nor does Zero-X make any warranty as to the accuracy or reliability of any information obtained through Zero-X (including third party content), that any defects in the Zero-X products or services be corrected or that the Zero-X products or Zero-X services will be compatible with any other specific hardware or service.

Further, Zero-X does not warrant that Zero-X products or services or Zero-X servers that provide you with data and content are free of viruses or other harmful components.

Zero-X also assumes no responsibility for and shall not be liable, for any damages caused by viruses that may infect your Zero-X. In the event of any loss, damage or injury, you will not look to Zero-X to compensate you or anyone else. You release and waive for yourself and your insurer all subrogation and other rights to recover against Zero-X arising as a result of the payment of any claim for loss, damage or injury.

Zero-X equipment and services do not cause and cannot eliminate occurrences of certain events, including, and Zero-X makes no guarantee or warranty, including any implied warranty of merchantability or fitness for a particular purpose, that the Zero-X equipment and services provided will detect or avert such incidents or their consequences.

Zero-X does not undertake any risk that you or property, or the person or property of others, may be subject to injury or loss if such an event occurs. The allocation of such risk remains with you, not Zero-X.

Other than the above product warranty for the Zero-X products, its suppliers disclaim all warranties of any kind, whether express, implied, or statutory, regarding the Zero-X services, including any implied warranty of title, merchantability, fitness for a particular purpose, or non-infringement of third party rights.

Because some jurisdictions do not permit the exclusion of implied warranties, the last sentence of this section may not apply to you.

Zero-X hereby further expressly disclaims all liability for any claims for service failures that are due to normal product wear, product misuse, abuse, product modification, improper product selection or your non-compliance with all applicable federal, state or local laws.

This warranty and warranty disclaimer give you specific legal rights, and you may have other rights that vary by state, province, or country. Other than as permitted by law, Zero-X does not exclude, limit or suspend other rights you have, including those that may arise from the nonconformity of a sales contract.

For a full understanding of your rights, you should consult the laws of your state, province, or country. For our Australian customers: Please note that this warranty is in addition to any statutory rights in Australia in relation to your goods which, pursuant to the Australian Consumer Law, cannot be excluded.

LIMITATIONS OF ZERO-X LIABILITY

Under no circumstances will Zero-X be liable in any way for any content, including, but not limited to, the loss of content, any errors or omissions in any content, or any loss or damage of any kind incurred in connection with use of or exposure to any content posted, emailed, accessed, transmitted, or otherwise made available via Zero-X.

Zero-X liability for damages, especially for breach of duty or obligation, delay in performance, non-performance, or malperformance shall be precluded, except when these are due to negligent breaches of any significant contractual duty or obligation on the part of Zero-X. Any liability for negligence is limited to direct losses usually and typically foreseeable in such case. Should the claim for damages be based on wilful or grossly negligent breach of contractual duty or obligation on the part of Zero-X, the preclusion and limitation of liability mentioned in the preceding sentences will not apply. The preceding preclusion and limitation of liability will also not apply to claims for damages arising out of loss of life, bodily injury or health impacts for which Zero-X may be liable, or for non-contractual liability.

Some states and countries do not allow the exclusion or limitation of incidental or consequential damages, so the above limitation or exclusion may not apply to you. Additionally, this provision is not intended to limit Zero-X's liability in the event of Zero-X's wilful or intentional misconduct.

REPLACEMENT PARTS

We understand that it is not always easy learning how to control an RC car. In rare occurrences, a 'close call' can turn into a crash course. Accidents happen!

To thank you for your support of Zero-X and your RC Car purchase, we would like to help you build your confidence in learning how to drive your RC car by offering you 50% off your first two orders of spare parts.

Simply make your spare parts purchase via our website and use the codes in the coupons to redeem and use your discount.

Visit www.zero-x.com.au or www.zero-x.co.nz to make your purchase.

THANK YOU FOR YOUR SUPPORT!
PLEASE VISIT OUR WEBSITE AND
USE PROMO CODE:
OOPSIBROKEIT
to receive
50% OFF
your spare parts purchase!

THANK YOU FOR YOUR SUPPORT!
PLEASE VISIT OUR WEBSITE AND
USE PROMO CODE:
OOPSIBROKEITAGAIN
to receive
50% OFF
your spare parts purchase!

ZERO-X

ANOTHER
DIRECTED
BRAND

www.zero-x.com.au | www.zero-x.co.nz



All Images, Information and Content are
Copyright © 2023 Directed Electronics
Australia Pty Ltd. All Rights Reserved.

www.directed.com.au | www.directed.co.nz

© Zero-X v1.0 2023